

OPTEK 1000



**AXOMATIC**®

**GROUP**

**and PAN TECNICA DIVISION**  
*Tube Filling, Cartoning And Process Solutions*

AXOMATIC Filling and Process Solutions leader da sempre nel settore delle macchine intubettatrici, mescolatori sottovuoto e macchine di processo è presente sui più competitivi mercati mondiali.

Premiata dal costante successo dei propri prodotti, dotati delle più avanzate tecnologie quali anticipatori di domande sempre più sensibili ai contenuti dell'innovazione.

Il servizio post vendita qualifica anche sotto il profilo commerciale, l'eccellenza della società Axomatic, verso il cliente.

Axomatic has always been a leader in the filling and process solution sector, and is present in the most competitive and important world markets.

The company is proud of the constant success of its product, which are equipped with the most advanced technology and anticipate increasingly more detailed requests concerning innovation.

Even under the sales profile, the after-sales service is proof of the excellent service that Axomatic gives its clients.

AXOMATIC Filling and Process Solutions war schon immer eines der führenden Unternehmen im Bereich der Tubenfüll- und -verschleißmaschinen sowie der Misch- und Homogenisieretechnik. Die Produkte von AXOMATIC sind auf allen wichtigsten Weltmärkten vertreten und durch ihr attraktives Preis - / Leistungsverhältnis überaus konkurrenzfähig.

AXOMATIC ist durch die konstante Qualität und Zuverlässigkeit seiner Produkte geprägt, die stets über modernste Technologien verfügen und bei denen auf Innovation größten Wert gelegt wird. So ist man bei AXOMATIC auch stets bereit, auf Sonderwünsche des Kunden einzugehen.

Ein weiterer wesentlicher Punkt, den man bei AXOMATIC nie außer acht gelassen hat, ist der Kundenservice, der durch ein weltweites Netz von Vertretungen und Servicetechnikern gewährleistet wird.





- ① Pannello di comando con Touch Screen a colori
- ② Quadro elettrico apribile
- ③ Volantino regolazione altezza magazzino tubetti
- ④ Caricatore tubetti automatico dalla scatola
- ⑤ Uscita tubetti
- ⑥ Scatola di raccolta sfridi per tubetti in politene
- ⑦ Tramoggia prodotto
- ⑧ Iniettore discendente
- ⑨ Sistema di chiusura per tubetti in metallo
- ⑩ Sistema di chiusura a pinze calde per tubetti in politene e laminato
- ⑪ Sistema di chiusura ad aria calda per tubetti in politene e laminato



- ① Control panel with colour Touch Screen
- ② Handwheel for electric cabinet opening
- ③ Handwheel for tube loader adjustment
- ④ Automatic tube loader from the tray
- ⑤ Tube ejection
- ⑥ Discharge container for trimming waste
- ⑦ Product hopper
- ⑧ Diving nozzle
- ⑨ Closure system for metal tubes
- ⑩ Closure system by hot jaws for plastic and laminated tubes
- ⑪ Closure system by hot air for plastic and laminated tubes



- ① Panel de mando con pantalla táctil de colores
- ② Mango apertura cuadro eléctrico
- ③ Volante regulación altura almacén tubos
- ④ Cargador automático tubos desde caja de cartón
- ⑤ Salida tubos
- ⑥ Recogida retales para tubos en polietileno
- ⑦ Tolva producto
- ⑧ Inyector descendiente
- ⑨ Sistema de cierre para tubos metálicos
- ⑩ Sistema de cierre por pinzas calientes para tubos en polietileno y laminado
- ⑪ Sistema de cierre por aire caliente para tubos en polietileno y laminado



- ① Funktionstastatur mit beruehrungsaktivem Farbbildschirm Kessel
- ② Schalttschrank
- ③ Handrad zur Hoeheneinstellung des Leertubenmagazins
- ④ Automatische Tubenbeschickung aus dem Leertubenmagazin
- ⑤ Tubenauswurf
- ⑥ Auffangbehälter fuer abgeschnittene Tubenzalreste
- ⑦ Vorratsbehälter
- ⑧ Tauchdüse
- ⑨ Kaltstationen fuer Metalltuben
- ⑩ Heizbackenverschliessaggregat fuer PE-Tuben
- ⑪ Heissluftverschliessaggregat fuer PE-und Laminattuben



- ① Panneau de commandes à couleurs avec touches sensibles
- ② Poignée d'ouverture tableau électrique
- ③ Volant réglage hauteur magasin tubes
- ④ Chargeur tube automatique à partir de la boîte
- ⑤ Sortie tube
- ⑥ Récupération des découpes tubes
- ⑦ Trémie produit
- ⑧ Injection descendante
- ⑨ Système de fermeture pour tube en métal
- ⑩ Système de fermeture à pinces chauffantes pour tubes en polyéthylène et laminé
- ⑪ Système de fermeture air chaude pour tubes en polyéthylène et laminé

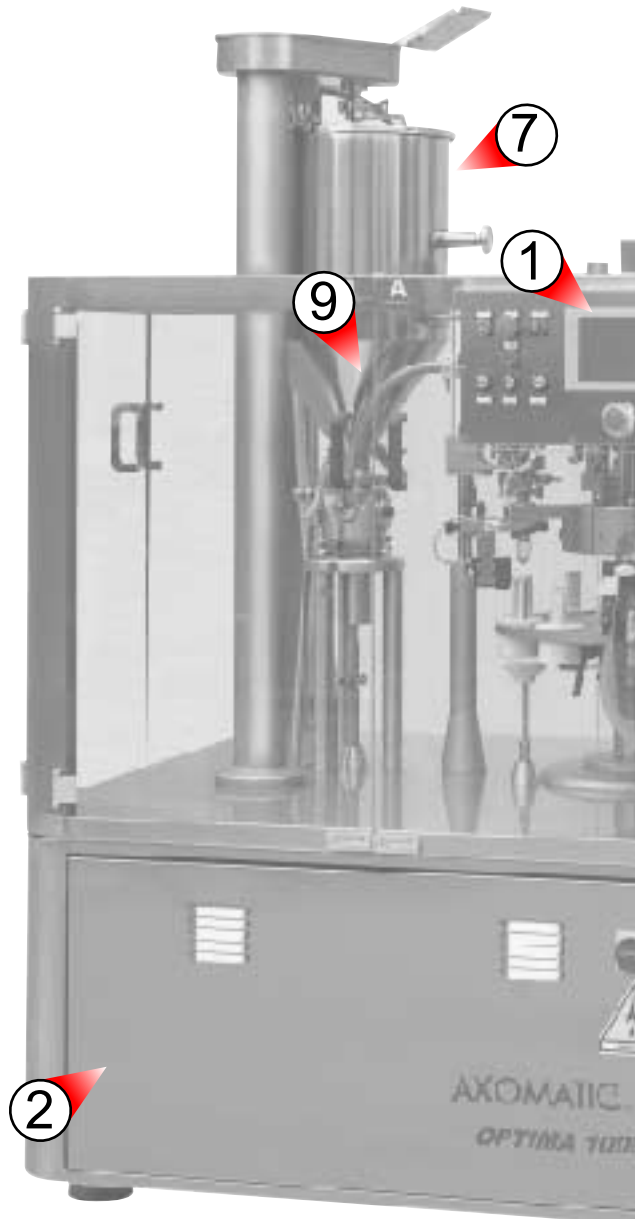



**INIETTORE DISCENDENTE A CORSA REGOLABILE DI 130 mm**

**DIVING FILLING NOZZLE ADJUSTABLE STROKE 130 mm**

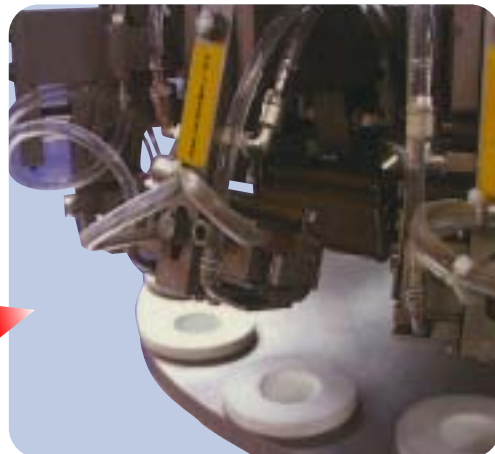
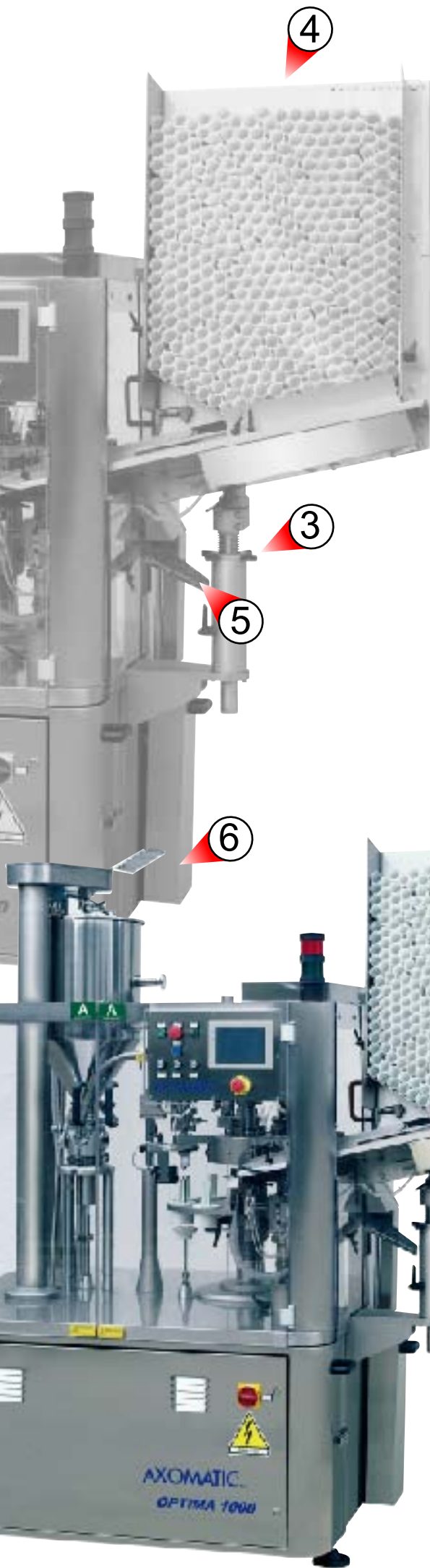



10



 SISTEMA DI CHIUSURA A PINZE CALDE PER TUBETTI IN POLITENE, LAMINATO E POLYFOIL  
 HOT JAWS SEALING SYSTEM FOR PLASTIC, LAMINATED AND POLYFOIL TUBES

**New Model**

**OPTIMA 1000**



11

 SISTEMA DI CHIUSURA AD ARIA CALDA PER TUBETTI IN POLITENE, LAMINATO E POLYFOIL  
 HOT AIR SEALING SYSTEM FOR PLASTIC, LAMINATED AND POLYFOIL TUBES

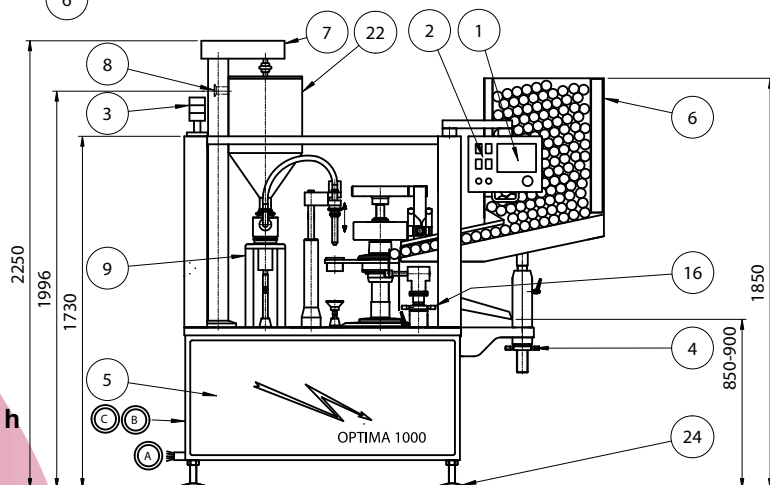
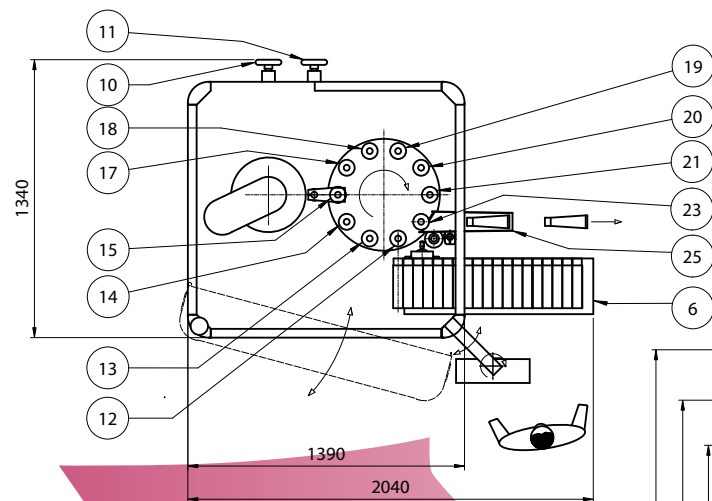

## OPTIMA 1000

- Velocità 5200 Pz / h / Speed up to 5200 Pcs / h
- Peso / Weight: 1150 kg

- 25 SCIVOLO ESPULSORE TUBETTI
- 24 PIEDINI DI APOGGIO IN ACCIAIO INOX
- 23 STAZIONE DI ESPULSIONE TUBI
- 22 TRAMOGGIA CAPACITÀ 50 Lt.
- 21 METALLO: PINZA DI CODIFICA  
POLITENE: FORBICE
- 20 METALLO: 3° PINZA OPERATIVA  
POLITENE: PINZA DI CODIFICA CON PINZE CALDE
- 19 METALLO: 2° PINZA OPERATIVA  
POLITENE: 3° PINZA CALDA/PINZA CODIFICA CON ARIA CALDA
- 18 METALLO: 1° PINZA OPERATIVA  
POLITENE: 2° PINZA CALDA/ARIA CALDA
- 17 METALLO: 1° PINZA  
POLITENE: 1° PINZA CALDA
- 16 VOLANTINO REGOLAZIONE RIBALTATORE
- 15 STAZIONE DI RIEMPIMENTO TUBI
- 14 STAZIONE DI ORIENTAMENTO TUBI
- 13 STAZIONE DI PULIZIA TUBI - AVVITATAPPI
- 12 STAZIONE DI CARICO TUBI - PRESSORE
- 11 VOLANTINO REGOLAZIONE INIETTORE
- 10 VOLANTINO REGOLAZIONE DOSE
- 9 GRUPPO DOSE
- 8 ATTACCO TUBO POMPA CARICO PRODOTTO
- 7 AGITATORE PRODOTTO
- 6 MAGAZZINO TUBI
- 5 QUADRO ELETTRICO
- 4 VOLANTINO REGOLAZIONE MAGAZZINO
- 3 INDICATORI ALLARMI MACCHINA
- 2 PANNELLO COMANDI
- 1 VISUALIZZAZIONE MESSAGGI CON "TOUCH SCREEN"

- 25 TUBE EJECTION CHUTE
- 24 STAINLESS STEEL BASE FOOT
- 23 TUBE EJECTION STATION
- 22 HOPPER CAPACITY 50 Lt.
- 21 METAL: CODING JAW  
POLYTHENE: CUTTER
- 20 METAL: 3° OPERATING JAW  
POLYTHENE: CODING JAW WITH HOT JAWS
- 19 METAL: 2° OPERATING JAW  
POLYTHENE: 3° HOT JAW/CODING JAW FOR HOT AIR
- 18 METAL: 1° OPERATING JAW  
POLYTHENE: 2° HOT JAW/HOT AIR
- 17 METAL: 1° JAW  
POLYTHENE: 1° HOT JAW
- 16 HAND-WHEEL FOR FILTER ADJUSTMENT
- 15 TUBE FILLING STATION
- 14 TUBE ORIENTATION STATION
- 13 TUBE CLEANING - CAPTIGHTENING STATION
- 12 TUBE LOADING STATION - TUBE PRESSER
- 11 HAND-WHEEL FOR INJECTOR ADJUSTMENT
- 10 HAND-WHEEL FOR DOSE ADJUSTMENT
- 9 DOSING GROUP
- 8 TUBE CONN. FOR PRODUCT FEEDING PUMP
- 7 PRODUCT STIRRER
- 6 TUBE LOADER
- 5 ELECTRIC PANEL
- 4 MANUAL DRIVE WHEEL
- 3 MACHINE ALARM INDICATOR
- 2 CONTROL PANEL
- 1 MESSAGES DISPLAY BY "TOUCH SCREEN"

**A**

CONSUMO ARIA:  
ATTACCO DA 3/8"

300 L/min a 6 bar per tubi metallo + optional  
350 L/min a 6 bar per tubi politene con pinze calde + optional  
450 L/min a 6 bar per tubi politene con aria calda + optional

AIR CONSUMPTION:  
CONNECTION 3/8"

300 L/min at 6 bar for metal tubes + optional  
350 L/min at 6 bar for polythene tubes with hot jaw + optional  
450 L/min at 6 bar for polythene tubes with hot air + optional

**B**

CONSUMO ACQUA:

3-4 L/min a 0.5 bar (solo per testa di chiusura per tubi in politene)  
OPTIONAL GRUPPO REFRIGERATORE

WATER CONSUMPTION:  
POTENZA INSTALLATA:

3-4 L/min at 0.5 bar (only for sealing head for polythene tubes)

3 fasi + terra + neutro

max 2 kW per tubi metallo + optional  
max 5 kW per tubi politene pinze calde + optional  
max 5.5 kW per tubi politene aria calda + optional

**C**

INSTALLED POWER:

3 phases + ground + neutral

max 2 kW for metal tubes + optional  
max 5 kW for polythene tubes with hot jaw + optional  
max 5.5 kW for polythene tubes with hot air + optional

# AXOMATIC<sup>®</sup> GROUP

**and PAN TECNICA DIVISION**  
*Tube Filling, Cartoning And Process Solutions*



STAB. E UFFICI: VIA EINSTEIN, 8 - I-20019 SETTIMO MILANESE (MI) - ITALY

TEL. +39-02-328.53.70 - FAX +39-02-335.02.894

E-mail: [sales@axomatic.com](mailto:sales@axomatic.com) - Web site: [www.axomatic.com](http://www.axomatic.com)



Diritti riservati a termine di legge - Riproduzione anche parziale vietata - AXOMATIC<sup>®</sup>  
si riserva di apportare qualsiasi modifica ritenuta migliorativa senza alcun preavviso