

00
50
13

AXOMATIC

AXOMATIC[®]
GROUP

and PAN TECNICA DIVISION
Tube Filling, Cartoning And Process Solutions



AXOMATIC Filling and Process Solutions leader da sempre nel settore mescolatori sottovuoto, intubettatrici e macchine di processo. Presente sui più competitivi mercati mondiali.

Premiata dal costante successo dei propri prodotti, dotati delle più avanzate tecnologie quali anticipatori di domande sempre più sensibili ai contenuti dell'innovazione.

Il servizio post vendita qualifica anche sotto il profilo commerciale l'eccellenza della società Axomatic verso il cliente.

Axomatic has always been a leader in the filling and process solution sector, and is present in the most competitive and important world markets.

The company is proud of the constant success of its product, which are equipped with the most advanced technology and anticipate increasingly more detailed requests concerning innovation.

Even under the sales profile, the post-sale service is proof of the excellent service that Axomatic gives its clients.

AXOMATIC Filling and Process Solutions war schon immer eines der führenden Unternehmen im Bereich der Tubenfüll - und - verschließmaschinen sowie der Misch - und Homogenisierertechnik. Die Produkte von AXOMATIC sind auf allen wichtigsten Weltmärkten vertreten und durch ihr attraktives Preis - / Leistungsverhältnis überaus konkurrenzfähig.

AXOMATIC ist durch die konstante Qualität und Zuverlässigkeit seiner Produkte geprägt, die stets über modernste Technologien verfügen und bei denen auf Innovation größten Wert gelegt wird. So ist man bei AXOMATIC auch stets bereit, auf Sonderwünsche des Kunden einzugehen.

Eir weiterer wesentlicher Punkt, den man bei AXOMATIC nie außer acht gelassen hat, ist der Kundenservice, der durch ein weltweites Netz von Vertretungen und Service technikern gewährleistet wird.



- ① Tramoggina per essenze
 - ② Valvole di ingresso polveri/liquidi
 - ③ Indicatore allarmi macchina
 - ④ Pannello di comando con Touch Screen a colori
 - ⑤ Valvola di scarico
 - ⑥ Valvola di fondo per carico e scarico prodotti
 - ⑦ Specola con lampada di illuminazione interna
- Diversi optional sono disponibili, quali:
- valvola di fondo a tre vie
 - sistema CIP
 - stampa dati
 - riscaldamento a vapore
 - esecuzioni speciali



- ① Small hopper for additive, perfumes etc.
 - ② Liquids/powders inlet valve
 - ③ Light for machine alarm
 - ④ Control panel with colour Touch Screen
 - ⑤ Discharge valve
 - ⑥ Bottom valve for products inlet/discharge
 - ⑦ Observation window with windscreen and lamp
- Several optional features available, as:
- Three-ways bottom valve
 - CIP system (Cleaning In Place)
 - Data printing
 - Steam heating
 - Special programs



- ① Tolva pequeña para esencias
 - ② Válvula de entrada líquidos/polvos
 - ③ Indicador alarmas máquinas
 - ④ Panel de mando con pantalla táctil de colores
 - ⑤ Válvula de descarga
 - ⑥ Válvula de fondo para la entrada/descarga de los productos
 - ⑦ Mirilla y lámpara inspección cuba
- Varios accesorios opcionales disponibles, como:
- Válvula de fondo a tres vías
 - Sistema CIP (Cleaning in Place)
 - Impresión datos
 - Calentamiento con vapor
 - Ejecuciones especiales



- ① Kleiner Vorlagebehälter für Additive, Parfumes etc.
 - ② Einlassventil für Flüssigkeiten und Pulver
 - ③ Warnlicht fuer Maschinenstoerung
 - ④ Funktionstastatur mit beruehrungsaktivem Farbbildschirm
 - ⑤ Kessel
 - ⑥ Produkteinlass-/auslassventil am Kesselboden
 - ⑦ Sichtfenster mit Beleuchtung
- Optionen auf Anfrage:
- 3-Wege-Ventil am Kesselboden
 - CIP-Reinigung (Clean-In-Place)
 - Datenausdruck
 - Aufheizen mit Wasserdampf
 - Sonderprogramme



- ① Petite trémie pour charger les essences
 - ② Vanne pour charger poudres/liquides
 - ③ Indicateur des alarmes de la machine
 - ④ Panneau de commandes à couleurs avec touches sensibles
 - ⑤ Vanne papillon pour l'évacuation des produits
 - ⑥ Vanne de fond pour l'entrée/évacuation des produits
 - ⑦ Hublot et lampe pour le control visuel
- Différentes options sont disponibles telles que:
- Vanne de fond de cuve à 3 voies
 - Système CIP (Nettoyage en place)
 - Impression des données de production
 - Chauffage par la vapeur
 - Exécutions spéciales

2

1

5



VALVOLA DI CARICO / SCARICO RASO
BOCCA DI TIPO SANITARIO (OPZIONALE)

SANITARY CHARGE / DISCHARGE
CENTRAL VALVE (OPTIONAL)





 FUSORI DA 5 Lt. A 2000 Lt.
 PRE-MELTERS FROM 5 UP TO 2000 Lt.



AXOMATIC

150
300



 PALE CONTRO-ROTANTI
 CONTRA-ROTATING BLADES

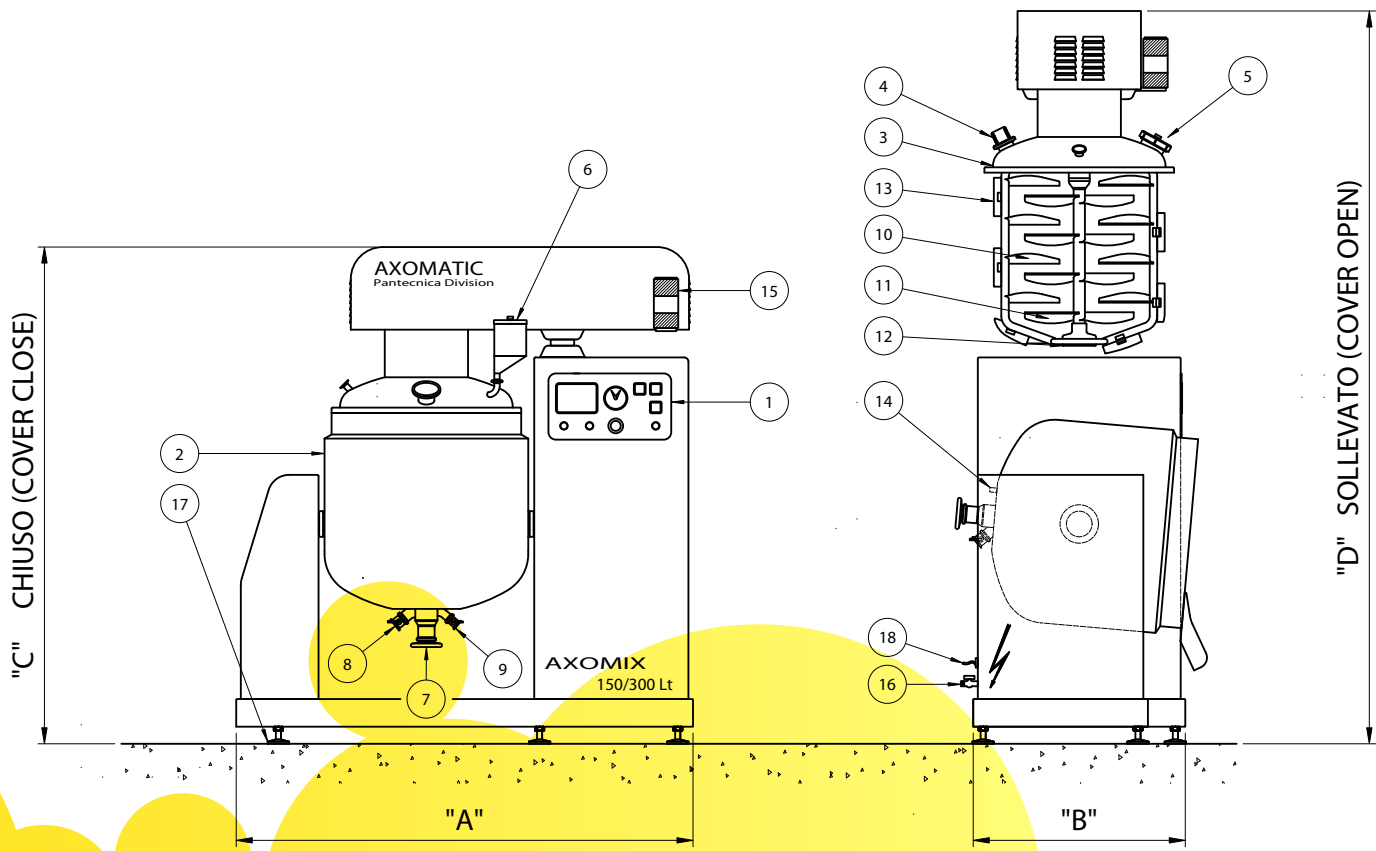

- 18 CONNESSIONE ELETTRICA
- 17 PIEDI REGOLABILI
- 16 RUBINETTO PER CONNESSIONE IDRAULICA
- 15 INDICATORE ALLARMI MACCHINA
- 14 SONDA TEMPERATURA PRODOTTO
- 13 RASCHIANTI
- 12 TURBINA
- 11 PALE MESCOLAZIONE VELOCE
- 10 PALE MESCOLAZIONE LENTA
- 9 CARICO/SCARICO ESSENZE LIQUIDI VALVOLA DI FONDO
- 8 CARICO/SCARICO PRODOTTO VALVOLA DI FONDO
- 7 VALVOLA DI FONDO
- 6 TRAMOGGINA ESSENZE
- 5 SPECOLA PER ISPEZIONE RECIPIENTE CON TERGICRISTALLO
- 4 LAMPADA PER ILLUMINAZIONE INTERNA RECIPIENTE
- 3 COPERCHIO
- 2 RECIPIENTE PRODOTTO
- 1 PANNELLO DI COMANDO

- 18 ELECTRIC CONNECTION
- 17 FOOT SILENT BLOCK
- 16 WATER CONNECTION
- 15 LIGHT FOR MACHINE ALARM
- 14 PROBE PRODUCT TEMPERATURE CONTROL
- 13 SCAPERS (PTFE MADE)
- 12 TURBINE FOR FAST AGITATOR
- 11 CONTRA-ROTATING BLADE AGITATORS
- 10 CONTRA ROTATING BLADE AGITATORS
- 9 INLET/OUTLET RAW MATERIAL VALVE
- 8 INLET/OUTLET PRODUCT VALVE
- 7 VALVE DISCHARGE PLUG VALVE
- 6 SMALL HOPER FOR ADDITIVE, PARFUMES ETC.
- 5 OBSERVATION WINDOW WITH WINDSCREEN
- 4 LIGHT FOR INTERNAL VESSEL ILLUMINATION
- 3 COVER
- 2 VESSEL
- 1 CONTROL PANEL

LITRI - LITRES

	150	300
MOTORE MESCOLAZIONE MOTOR FOR SLOW MIXING	1.5 Kw	1.5 Kw
MOTORE TURBINA MOTORS FOR TURBINE	7.5 Kw	7.5 Kw
POMPA DEL VUOTO VACUM PUMP	0.75 Kw	0.75 Kw
RESISTENZE RISCALDAMENTO HEATING ELEMENT	6 Kw	6 Kw

	"A"	"B"	"C"	"D"	Peso
AXOMIX 150 Lt	2140	990	2330	3220	Kg 1450
AXOMIX 300 Lt	2140	990	2330	3400	Kg 1850

AXOMATIC[®] GROUP

and PAN TECNICA DIVISION
Tube Filling, Cartoning And Process Solutions



STAB. E UFFICI: VIA EINSTEIN, 8 - I-20019 SETTIMO MILANESE (MI) - ITALY
TEL. +39-02-328.53.70 - FAX +39-02-335.02.894
E-mail: sales@axomatic.com - Web site: www.axomatic.com



Diritti riservati a termine di legge - Riproduzione anche parziale vietata - AXOMATIC[®]
si riserva di apportare qualsiasi modifica ritenuta migliorativa senza alcun preavviso